

HOGSBACK LANE ACCESS STUDY

Opportunities for Safer Alternative Transportation to the Rocky River Reservation

FINAL REPORT

March 22, 2007

Prepared for:
City of Lakewood Department of Planning
City of Cleveland City Planning Commission
Cleveland Metroparks
Kamm's Corners Development Corporation

Prepared by:
Behnke Associates, Inc.
Burgess & Niple, Inc.

TABLE OF CONTENTS

| | |
|---|----|
| Table of Contents | 1 |
| Table of Figures | 1 |
| Acknowledgements | 3 |
| Introduction | 5 |
| Terminology | 6 |
| Existing Conditions | 6 |
| Public Input | 7 |
| Public Meeting #1 | 8 |
| Public Meeting #2 | 8 |
| Public Meeting #3 | 9 |
| Public Input Conclusions | 9 |
| Recommendations | 11 |
| Master Plan | 11 |
| Hogsback Lane | 13 |
| Signage | 13 |
| Priorities | 14 |
| Conclusion | 16 |
| Referenced Standards | 17 |
| Funding Sources | 17 |
| Appendix 'A' Traffic Signalization at the Intersection of Riverside Drive & Hogsback Lane | 18 |

TABLE OF FIGURES

| | |
|--|----|
| 1: Bikeway Classifications | 21 |
| 2: Regional Map | 22 |
| 3: Rocky River Reservation 2006 Vehicular Traffic Counts | 23 |
| 4: Photo Key Map | 24 |
| 5: Existing Constraints | 25 |
| 6: Existing Opportunities | 26 |
| 7: Study Area Average Daily Traffic Counts | 27 |
| 8: Existing Topography & Soils | 28 |
| 9: Existing Green Space | 29 |
| 10: Public Meeting #1 and #2 Ideas | 30 |
| 11: Public's Preference for Existing Interstate 90 Crossings | 31 |
| 12: Public's Preference for Pedestrian Bridge Location | 32 |
| 13: Public's Traffic Calming Priorities | 33 |
| 14: Public's Favorite Destinations | 34 |
| 15: Public's Preferred Routes to Hogsback | 35 |
| 16: Public's Preference for Hogsback Lane Improvements | 36 |
| 17: Geographic Distribution of Public Meeting Participants | 37 |



18: Summary of Recommendations.....38
19: Master Plan39
20: West 159th Street Bridge Widening Options40
21: Riverside Drive Bridge Widening Options.....41
22: Multi-User Bridge.....42
23: Traffic Calming Examples.....43
24: All-Purpose Path Along Riverside Drive44
25: Hogsback Intersection Improvements & Riverside Bike Lanes...45



ACKNOWLEDGEMENTS

The City of Lakewood Planning Department assembled a Steering Committee to guide the planning process and development of the report for the study. Sincere appreciation is extended to the members:

Tom Jordan, Director, City of Lakewood Department of Planning and Development

Aldryck Bennett, Assistant Director, City of Lakewood Department of Planning and Development

Dick Kerber, Director of Planning and Construction, Cleveland Metroparks

Marty Cader, City Planner, City of Cleveland, City Planning Commission

Michael Bosak, City Planner, City of Cleveland, City Planning Commission

Steve Lorenz, Executive Director, Kamm's Corners Development Corporation

David Walker, Neighborhood Real Estate Planner, Kamm's Corners Development Corporation

The Honorable Timothy McGinty, Judge, Cuyahoga County Common Pleas Court

Barbara Kelly, City Planner, City of Lakewood Department of Planning and Development

Tom Zarfoss, Principal Emeritus, Behnke Associates, Inc.

Matt Hils, Principal, Behnke Associates, Inc.

Neil Chase, Senior Project Manager, Burgess and Niple, Inc.

The following agencies generously provided data for existing condition inventory and map generation:

City of Cleveland Planning Commission

City of Lakewood, Department of Planning and Development

Cleveland Metroparks

Cuyahoga County Planning Commission

Northeast Ohio Area Coordinating Agency

Funding for the project was provided by the Northeast Ohio Area Coordinating Agency.

The Committee extends many thanks to the members of the public who took the time to attend the public meetings, and provide their input.





INTRODUCTION

The Cleveland Metroparks' Emerald Necklace is the envy of many American cities. While the Metroparks system is accessible to the residents of Northeast Ohio by car, the most fortunate beneficiaries are those residents within walking and biking distance of the parks. Today's car-centered infrastructure, however, sometimes makes safe access to the parks on foot or by bicycle difficult.

Between 1910 and 1930, the suburban neighborhoods of Lakewood and West Park became established. During the same period, William Stinchcomb assembled land for, and opened up to the public one of the Cleveland Metropolitan Park District's first parks, the Rocky River Reservation.

By the 1940's, the automobile became the dominant method of transportation. In 1956, the Interstate Highway Act was signed, and the Interstate System was born. The automobile and interstates had many benefits, but were not without social costs. Interstate 90 sliced through the West Park and Lakewood neighborhoods. Today, the combination of Interstate 90 and streets designed strictly for the automobile has generated many of the challenges this planning study addresses.

The Hogsback Lane Access Study evaluates the current ability of local residents to use transportation other than motor vehicles to move within the Study Area, and to access the Rocky River Reservation, via Hogsback Lane. Where there are constraints, however, there also are opportunities; with a combination of public input and the Steering Committee's experience, this study proposes several solutions to provide greater and safer access to this jewel within the study area's backyard.



Typical Vehicular Intersection



TERMINOLOGY

To avoid confusion, it is important to understand alternative transportation terminology. Figure 1 defines Bikeway Classifications. For purposes of this report, the term “multi-user” will refer to a person using any form of alternative transportation, and “bikeway” will mean any type of alternative transportation route.

It is unclear where State Route 237 changes its local name from Riverside Drive to Rocky River Drive. This report will refer to both segments as Riverside Drive.

EXISTING CONDITIONS

The Study Area consists of the 725-acre site bounded by Madison Avenue on the north, Riverside Drive (and topographically, the Rocky River Reservation valley edge,) on the west, Munn Road on the south, and Warren Road on the east, as shown on Figure 2.

By compiling Geographical Information System (GIS) data, and with a series of walk- and drive-throughs of the study area, the consultants documented current conditions within and around the study area, relative to alternative transportation.

Figure 2 displays the study area, its regional context, and its direct relationship to the Rocky River Reservation. Hogsback Lane is one of six evenly-distributed access points along the northern end of the reservation. Hogsback is used heavily, year-round, as shown in Figure 3, Cleveland Metroparks’ 2006 vehicular traffic counts.

Current constraints and opportunities are documented in Figures 4 through 6. Interstate 90, a major constraint, cuts through the heart of the project area, and creates a barrier for those multi-users who want to get from one side to the other. Figure 10 and the Recommendations section discuss opportunities and constraints further.

In order to determine the safest multi-user routes, vehicular traffic volumes must be considered. Traffic counts for each leg of key intersections in the study area are shown in Figure 7. Traffic volume is highest along conduits to and from Interstate 90, and along the arterial streets of Hilliard, Riverside, Warren, and Madison. When alignments do need to use these intersections, traffic calming measures should be considered (Figure 22.)



Figure 8, Existing Topography and Soils, demonstrates the difficulty in building a stable access route from arterial streets on the “upland plateau” down into the Rocky River valley. Steep slopes limit options for access roads to the valley, and unstable soils line the majority of those slopes, making roadbed stabilization a costly task. Hogsback is no exception to these conditions.

Since the Lakewood and West Park neighborhoods within the study area were constructed before automobiles became a major mode of transportation, parcels are small, and there is little remaining green space. For this reason, the few remaining greenspaces should be utilized to their maximum benefit. While some are currently well used, such as Impett Park and McBride Park, other areas, such as the leftover ODOT right of way along South Marginal, could become green corridors to Hogsback. A series of green spaces are grouped together in the “core” of the study area, as shown in Figure 9.

Hogsback Lane is a two-lane roadway that is steep (the grade on the majority of it exceeds 5% (5 feet of fall over 100 feet of length,) with portions as steep as 7%,) feels narrow (approximate width is 22’,) and is in poor condition. While some drainage improvements were made to the side swales and inlet basins in 2006, ground and/or surface water runs over some areas, exacerbating pavement base drainage problems and creating a surface freezing hazard in the winter. Even with these current limitations, the Hogsback experience can be very pleasant, framed by woods and a resident’s perennial garden at the top, opening up to a prairie (fill from Interstate 90 construction,) on the north side half way down, and offering views of the Rocky River at the bottom. Except for a very narrow right-of-way at the top 500’, there is ample room along the rest of the lane to pull the roadbed away from the edge of the slipping hillside and to create an even better experience with a meandering route down into the reservation.



An opportunity for an all-purpose trail through green space along South Marginal.



PUBLIC INPUT

A series of three public meetings was held, to determine what issues are most important to the residents within the study area, and to determine how to best deal with those issues.

Public Meeting #1

At the first public meeting, the consultant presented the figures and conditions described in the Existing Conditions portion of this report. The meeting facilitators then divided the participants into small groups to discuss and generate a list of issues and concerns. Participants were encouraged to brainstorm for ideas, and remember that no idea was a bad idea. At the end of the meeting, each table reported to the overall group their concerns, ideas, and desires.

Public Meeting #2

The second public meeting consisted of three parts:

- 1) The consultant presented a summary list of ideas from the first public meeting for the “Upland Area”, which consists of the entire study area, except Hogsback Lane. After the presentation, the public was asked for any ideas that were missed at the first meeting, clarifications of the listed ideas, or any new ideas; these were all recorded. The public then expressed support by placing sticky dots next to their most-preferred ideas.

Figure 10 records the list of ideas and the level of support for each item. In an effort to best assess the public’s true desires for the study area, the consultant encouraged the participants to vote without considering the feasibility of each idea. Figure 10 does, however, begin to evaluate feasibility, with pro and con columns.

- 2) To further clarify the public’s priorities, the participants answered the following questions by placing dots on separate maps:
 - a) “Where is the Best Existing Location to Cross Interstate 90?” (Figure 11) A majority indicated the Riverside crossing is preferred, with an equal number of the remaining votes falling to the McKinley bridge and the W. 165th/Woodward bridge.
 - b) “Where is the Best Pedestrian Bridge Location for Crossing Interstate 90?” (Figure 12) A slight majority of people preferred a pedestrian bridge located between W. 160th and Olive over one located at Niagara. This points to the desire for



a safe link between Hayes Elementary and St. Mark's Elementary, and their neighborhoods.

- c) "Where is Traffic Calming Most Important?" (Figure 13) A significant number of participants wanted to see McKinley traffic slowed down, but a solid majority of votes called for calming along Riverside Drive.
 - d) "What are the Most Important Destinations?" (Figure 14) The attendees made clear that Hogback is the destination everyone is interested in.
- 3) The public's final input for the meeting dealt directly with routes to Hogsback Lane and improvements to Hogsback itself. Participants traced on individual maps of the study area the route they would like best from their residence to Hogsback. The combination of those routes is shown on Figure 15.

Participants also selected one of the six Hogsback Lane Improvement Options shown in Figure 16. The vast majority preferred maintaining two-way vehicular traffic and dedicated pavement for multi-users. Of that majority, slightly more than half called for the same design as exists at the Rockcliff Road entry: a 14 foot all purpose trail, separated from two vehicular lanes by a 5 foot buffer.

Public Meeting #3

The consultant presented a draft version of this report for discussion, comments, and clarifications. The meeting attendees generally supported all the report's recommendations.

Public Input Conclusions

At all three public meetings, the participants made it very clear that out of all the study area issues described above, the improvement of Hogsback Lane was the participants' highest priority. Although the meeting attendees were not an even representative sampling of the overall study area (See Figure 17,) they were clearly the ones who care most about the Study, since most of them live closest to Hogsback.

While the "Hogsback representation factor" may have skewed overall public opinion about movement through the study area and access to the reservation, several overall themes, in addition to improving Hogsback Lane, emerged from the public meetings:

- 1) The public desires a safer multi-user crossing over Interstate 90 in the area between Hayes Elementary School and St. Mark's School.



- 2) Multi-users traveling to Hogsback Lane generally favor moving through the study area from east to west, to Riverside Drive, (as opposed to crossing Interstate 90 before Riverside, for those north of Interstate 90,) and traveling along Riverside Drive to Hogsback Lane.
- 3) The public prefers an all-purpose trail along Riverside Drive, wherever there is room. Where there is not room, bike lanes would be a welcome improvement.
- 4) The multi-user experience along Riverside Drive could be greatly enhanced with overlooks into the reservation.
- 5) Since Riverside Drive is used heavily by both multi-users and vehicles, traffic calming along Riverside is important for multi-use access to and along Riverside Drive.
- 6) While Riverside Drive was recently upgraded, users still are not comfortable with its intersection with Hogsback Lane. Options for traffic calming and circulation improvements to the intersection must be examined.



Public Meeting #2



RECOMMENDATIONS

The recommendations of the Hogsback Lane Access Study directly support the ideas and concerns raised in, and the conclusions drawn from the public meetings. These recommendations are in the form of a summary table (Figure 18,) master plan (Figure 18a,) and more detailed studies of key areas in the plan (Figures 19-24.)

Master Plan Recommendations

The backbone of the plan consists of a variety of bikeways that move users through the study area, to the Rocky River Reservation.

- 1) **A signed bike route (signed shared roadway,) along Hilliard Avenue** directs people from northeast of the study area to Riverside Drive.
- 2) **Signed bike routes on Carabel Avenue and Lakewood Heights Boulevard** pick users up from the northeast quadrant of the study area, and directs them across Interstate 90, along an all-purpose trail parallel to South Marginal, onto a signed bike route on Lakewood Heights Boulevard, to Riverside Drive.

Users could either cross Interstate 90 on a widened West 159th Street Bridge (see Figure 20 for widening options,) or a new multi-user bridge, connecting Olive Avenue and 160th Street (see Figure 21.)

The all-purpose trail takes advantage of the unused green space along South Marginal, and connects residents to McBride Park.

- 3) **A combination of signed bike route on Edgecliff Avenue and all purpose path through Impett Park and along 153rd Street** picks multi-users up from the southeast quadrant of the study area, moves them through the available green space, and directs them to Riverside Drive.
- 4) Residents in the **southwest quadrant** can take their side streets straight to Riverside Drive.
- 5) **Bike lanes along Riverside Drive, south of Hogsback Lane,** move multi-users in the south half of the study area to and from Hogsback Lane. (See Figure 25.) The current 36'+/- pavement width allows for 5' bike lanes in both directions, which leaves 26' for two vehicular lanes. On-street parking will need to be eliminated to create enough room for the lanes. Currently, no parking is allowed on either side of Riverside Drive, between Munn Road and McKinley Avenue.



Vehicular traffic along Riverside Drive is heavy, particularly south of McKinley Avenue, due to Interstate 90 users. The plan calls for traffic calming measures in conjunction with the bike lanes. Some traffic calming methods that could be implemented along Riverside Drive include colored and/or textured pavement at intersections, raised intersections, speed humps, and speed monitoring. See Figure 22.

- 6) **An all-purpose trail along Riverside Drive, north of Hogsback Lane**, allows multi-users in the north half of the study to travel to and from Hogsback Lane. Along some portions of Riverside Drive, there is room to build the trail off of the roadway. In other areas where the Rocky River valley edge directly abuts the west edge of Riverside Drive, the path will use some of the wide 36' two-lane road, as shown in Figure 23.

In order for users to traverse Riverside Drive to and from the trail safely, this report recommends using a combination of traffic calming and well-defined crosswalks at each intersection. Appropriate methods to accomplish this include colored and/or textured pavement at intersections or on crosswalks, raised intersections, and/or raised crosswalks. The sections of trail that use some of the Riverside Drive roadway will effectively act as neckdowns or chokers, and slow traffic. See Figure 22.

A contiguous all-purpose trail along Riverside Drive, north of Hogsback Lane, will require the bridge across Interstate 90 to be widened. Figure 24 shows widening options; Option 1 is the more-likely option, since this report recommends building one path on the west side of Riverside Drive.

Cleveland Metroparks and the Cities of Lakewood and Cleveland should coordinate which side of Riverside Drive and Hogsback Lane (see Hogsback Lane recommendations, below,) the trails will be built, to minimize street crossings.

- 7) Several **overlooks along the Riverside Drive trail** could offer not only exquisite views of the valley and wildlife residing in the Hilliard Road Bridge, but also places of respite and opportunities for interpretive displays.
- 8) For those users seeking alternative routes into the reservation, **re-establishing the Sharkey's Hill and Cow Path foot trails** would provide opportunities for hikers, cross country runners, and mountain bikers to take the path less traveled. An example of this is demonstrated in Figure 23. The trails would need to meet minimum requirements, as set by Cleveland Metroparks; re-



establishment would include minor clearing, minor regrading to create a minimum 3 foot width, slope stabilization, and signage. Users could also benefit from better-defined trails at the bottom of these footpaths.

Hogsback Lane Recommendations

Public input indicates a very strong desire for Hogsback Lane to be upgraded to a 24' wide road for two-way vehicular traffic and a separate all-purpose trail, similar to the Rockcliff Drive entry improvements. Options 2 and 3, in Figure 16 and in Figure 25 show this preferred condition.

While this major capital improvement would create a much more pleasant and safer experience for all vehicles and multi-users on Hogsback Lane, the Riverside Drive intersection with Hogsback Lane remains unsatisfactory to many Metroparks users, who have expressed a need for traffic calming and improved safety, despite the recent Riverside Drive reconstruction.

This study has examined the feasibility of a traffic signal at the intersection, but per Appendix A, a signal is not justifiable. Another option is to construct a roundabout, as shown in Figures 22 and 25. A roundabout configuration at the intersection would force vehicles to reduce their speeds, but keep traffic moving. For a single-lane urban highway, a stop-controlled intersection (similar to the current Hogsback Lane intersection,) converted to a roundabout can expect a 69 percent reduction in total crashes and a 80 percent reduction in injury crashes (Source: NYSDOT Study October 2003.)

A roundabout has several benefits and tradeoffs, with respect to pedestrian accessibility. With the installation of island refuges (as shown in Figure 25,) multi-users crossing Riverside Drive to and from the Hogsback Lane all-purpose path would only have to cross a single lane of traffic at a time. However, multi-users would still have to assess gaps in the moving traffic, as opposed to an intersection with a traffic signal, where they would be protected by the signal.

Signage Recommendations

Standard way-finding signage should be developed to direct users through the study area. The routes could be branded with a simple, easily recognized graphic and name. Ideas for names include “Roads to the Reservation”, “Gate to the Greenway”, or “The 3R Route.”



Priority Recommendations & Costs

The master plan offers an exciting overview of how to help multi-users travel more safely from their residence to the Rocky River Reservation. Since the plan is too large to implement all at once, and since funding for components of the plan will come from different sources, priorities should be set. All costs listed below are approximate, and should be viewed as order of magnitude costs only.

- The overriding priority for public meeting participants was the **improvement of Hogsback Lane**. Due to space constraints at the top of Hogsback Lane, geotechnical issues, and the length of the lane, though, this will be a costly capital improvement. Cost: \$2 million.
- Improving the safety of the **Hogsback Lane/Riverside Drive intersection** was another top priority for meeting participants. The roundabout proposed in this report is also an expensive project. Cost: \$400,000.
- **Moving people safely along the main multi-user Riverside Drive corridor** is the next logical concern. While all of the north-of-Hogsback Lane improvements create a sizeable project, individual components could be installed as funding allows. The south-of-Hogsback Lane improvements are considerably less costly, particularly the bike lanes, with no traffic calming measures.
 - All-purpose trail cost: \$350,000.
 - North-of-Hogsback Lane intersection traffic calming and crosswalks cost: \$20,000 per intersection.
 - Riverside Drive bridge-widening, Option 1 cost: \$700,000.
 - Riverside Drive bridge-widening, Option 2 cost: \$1.0 million.
 - Bike lanes cost: \$10,000.
 - South-of-Hogsback Lane traffic calming cost: \$50,000 to \$100,000.
- Creating the **signed bikeway network**, as shown in the master plan, is very feasible from a cost standpoint, as it only requires route signage and a short section of all-purpose trail in Impett Park. Cost: \$25,000.



- One caveat to the ease of creating the routes is if the Carabell Avenue and Lakewood Heights Boulevard routes direct users over the **existing 159th Street bridge**, the existing walks on the bridge do not meet current Ohio Department of Transportation (ODOT) and American Association of State Highway Transportation Officials (AASHTO) standards for all purpose trails.
 - W. 159th St. bridge-widening, Option 1 cost: \$500,000.
 - W. 159th St. bridge-widening, Option 2 cost: \$800,000.
- The other solution to the Interstate 90 crossing issue, the **multi-user bridge**, would provide a safer, more pleasant user experience, but would be more expensive. Cost: \$1.2 million.
- The cost for rehabilitating the **Sharkey's Hill and Cow Path** footpaths could vary widely, depending on the extent of work performed on them. Most, if not all of the work could be performed by local volunteer trail group(s). Cost for contractor to implement improvements: \$35,000.
- **Overlooks along Riverside Drive** could also vary widely in size, type, and quality of materials. Cost could range from \$2,500 to \$50,000 or more, per overlook.



CONCLUSION

The Cleveland Metroparks is a highly valued asset to many Clevelanders. Those residents within walking, running, or biking distance of a reservation are especially fortunate, and should have the opportunity to access it as safely as possible. Improvements to accessing the Rocky River Reservation will also benefit multi-users moving from point to point within the local neighborhoods. The implementation of the following key elements of the master plan will make the desirable Lakewood and West Park neighborhoods even more valuable communities:

- ❑ Create a network of bikeways to direct residents to and from Riverside Drive.
- ❑ Allow safer travel on Riverside Drive with an all-purpose trail and bike lanes.
- ❑ Improve multi-user and vehicular circulation at the intersection of Riverside Drive and Hogsback Lane.
- ❑ Upgrade Hogsback Lane to a 24' roadway with a 14' all-purpose trail.
- ❑ Improve access across Interstate 90 with widened existing bridges or a new multi-user bridge.
- ❑ Increase access to the Rocky River Reservation by re-establishing existing footpaths.

With the concerted effort of concerned citizens and committed local officials, these exciting concepts can become reality.



Pedestrians enjoying a walk on Hogsback Lane



REFERENCED STANDARDS

This study has relied upon the following standards for some of its information and recommendations:

- ❑ AASHTO Guide for the Development of Bicycle Facilities, 1999.
- ❑ ODOT Design Guidance for Independent Bicycle Facilities.
- ❑ ODOT Design Guidance for Roadway-Based Bicycle Facilities.
- ❑ ODOT Location & Design Manual Volume 1, January 25, 2007.
- ❑ ODOT Ohio Manual of Uniform Traffic Control Devices for Streets and Highways, 2005.
- ❑ Institute of Transportation Engineers Traffic Engineering Handbook, 5th ed.

FUNDING SOURCES

The following sources are available for funding multi-use projects:

- ❑ Federal Transportation Enhancement (TE) Program, via ODOT.
- ❑ Ohio Department of Natural Resources (ODNR), Division of Real Estate & Land Management (DRELM) Natureworks Program.
- ❑ ODNR, DRELM Land and Water Conservation Fund.
- ❑ ODNR, DRELM Clean Ohio Trails Fund.
- ❑ ODNR, DRELM Recreational Trails Program.

More information about funding from ODOT can be found at www.dot.state.oh.us/bike/New%20Downloads/FAQ%20Index.htm.

More information about funding from ODNR can be found at www.dnr.state.oh.us/grants.htm.



APPENDIX 'A' TRAFFIC SIGNALIZATION AT THE INTERSECTION OF RIVERSIDE DRIVE & HOGSBACK LANE

In order to justify the installation of a traffic signal at the intersection of Riverside Drive and Hogsback Lane one of the 8 warrants listed in the Ohio Department of Transportation's Ohio Manual of Uniform Traffic Control Devices would have to be satisfied. In order to perform a signal warrant analysis, a traffic count would have to be conducted at the intersection of Riverside and Hogsback. However, without performing a traffic count at Riverside and Hogsback, it is possible to estimate volumes at the intersection based on 2004 ODOT traffic counts along Riverside Drive (SR 237) just north at IR-90. Based on approximate intersection volumes using the methodology outlined below, it is highly unlikely that the intersection of Riverside and Hogsback warrants the installation of a traffic signal.

It is possible to approximate the hourly traffic counts on Riverside Drive at Hogsback Lane using 2004 ODOT traffic counts just a few blocks north on Riverside Drive (SR 237) at IR-90. It is also possible to approximate the Peak Hourly Volume on Hogsback using the provided Metroparks entrance traffic count data.

Riverside Traffic Volume: (see attached 2004 Traffic Counts)

Hogsback Traffic Volume: 1,522 Average Daily Traffic (ADT) – based on highest volume month (47,190 vehicles – July) of traffic in 2006

$$\begin{aligned} \text{Peak Hour Volume} &= \text{ADT} \times 0.10 \times D_F \\ &= 1,522 \times 0.10 \times 0.60 \\ &= 91 \text{ vehicles} \end{aligned}$$

One of 8 Traffic Signal Warrants from the Ohio Manual of Uniform Traffic Control Devices must be met if a traffic signal is to be installed at an intersection. The three following warrants are applicable to the Hogsback intersection: Eight-Hour Vehicular Volume; Four-Hour Vehicular Volume; and Crash Experience. Each of three warrants has certain traffic requirements with respect to peak hour volumes (VPH.)

In order to meet the criteria of Warrant 1 (Eight-Hour Vehicular Volume) one of the following three conditions from *Table 4C-1* would have to exist at the intersection of Riverside Drive and Hogsback Lane:

- (1) $VPH_{\text{Riverside}} > 500$ and $VPH_{\text{Hogsback}} > 150$



- (2) $VPH_{\text{Riverside}} > 750$ and $VPH_{\text{Hogsback}} > 75$
- (3) $VPH_{\text{Riverside}} > 600$ and $VPH_{\text{Hogsback}} > 120$

Because nearby traffic counts do not satisfy any of the above conditions, it is highly unlikely the intersection of Riverside Drive and Hogsback Lane would warrant a traffic signal based the Eight-Hour Vehicular Volume.

In order to meet the criteria of Warrant 2 (Four-Hour Vehicular Volume) the volume of cars on both approaches would have to have to intersect at a point above the *1 Lane & 1 Lane* line in *Figure 4C-1*. Because nearby traffic counts do not satisfy the above condition, it is highly unlikely the intersection of Riverside Drive and Hogsback Lane would warrant a traffic signal based the Four-Hour Vehicular Volume.

In order to meet the criteria of Warrant 7 (Crash Experience) the intersection of Riverside would have had to experience 5 or more crashes in a 12-month period and meet one the following two conditions from *Table 4C-1*:

- (1) $VPH_{\text{Riverside}} > 400$ and $VPH_{\text{Hogsback}} > 120$
- (2) $VPH_{\text{Riverside}} > 600$ and $VPH_{\text{Hogsback}} > 60$

Based on estimated traffic counts alone, it is highly unlikely that the traffic requirement of Warrant 7 could be satisfied, regardless of the number of crashes at Riverside Drive and Hogsback Lane.

In conclusion, it is highly unlikely that the installation of a traffic signal is warranted at the intersection of Riverside and Hogsback based on the analysis of estimated traffic volumes.

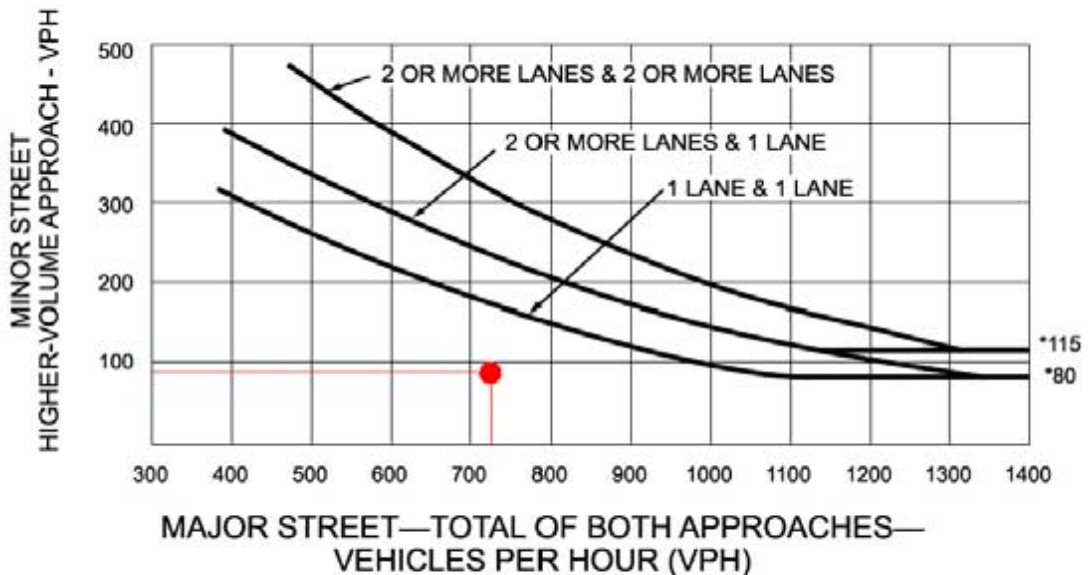

Table 4C-1. Warrant 1, Eight-Hour Vehicular Volume

| Condition A—Minimum Vehicular Volume | | | | | | | | | |
|---|--------------|--|------------------|------------------|------------------|---|------------------|------------------|------------------|
| Number of lanes for moving traffic on each approach | | Vehicles per hour on major street (total of both approaches) | | | | Vehicles per hour on higher-volume minor-street approach (one direction only) | | | |
| Major Street | Minor Street | 100% ^a | 80% ^b | 70% ^c | 56% ^d | 100% ^a | 80% ^b | 70% ^c | 56% ^d |
| 1 | 1 | 500 | 400 | 350 | 280 | 150 | 120 | 105 | 84 |
| 2 or more | 1 | 600 | 480 | 420 | 336 | 150 | 120 | 105 | 84 |
| 2 or more | 2 or more | 600 | 480 | 420 | 336 | 200 | 160 | 140 | 112 |
| 1 | 2 or more | 500 | 400 | 350 | 280 | 200 | 160 | 140 | 112 |

| Condition B—Interruption of Continuous Traffic | | | | | | | | | |
|---|--------------|--|------------------|------------------|------------------|---|------------------|------------------|------------------|
| Number of lanes for moving traffic on each approach | | Vehicles per hour on major street (total of both approaches) | | | | Vehicles per hour on higher-volume minor-street approach (one direction only) | | | |
| Major Street | Minor Street | 100% ^a | 80% ^b | 70% ^c | 56% ^d | 100% ^a | 80% ^b | 70% ^c | 56% ^d |
| 1 | 1 | 750 | 600 | 525 | 420 | 75 | 60 | 53 | 42 |
| 2 or more | 1 | 900 | 720 | 630 | 504 | 75 | 60 | 53 | 42 |
| 2 or more | 2 or more | 900 | 720 | 630 | 504 | 100 | 80 | 70 | 56 |
| 1 | 2 or more | 750 | 600 | 525 | 420 | 100 | 80 | 70 | 56 |

Figure 4C-1. Warrant 2, Four-Hour Vehicular Volume



*Note: 115 vph applies as the lower threshold volume for a minor-street approach with two or more lanes and 80 vph applies as the lower threshold volume for a minor-street approach with one lane.



Shared Roadways - Roadways with adequate width and in adequate condition for safe bicycle travel.

Signed Shared Roadways - Roadways identified by signing as preferred bike routes.

Bike Lane - A portion of roadway that has been designated by striping, signing, and pavement markings for the preferential or exclusive use of bicyclists.



Bike Path/All Purpose Trail/Shared Use Path - A path segregated from motorized traffic for use by bikes and pedestrians.

Bike Route/Bikeway - Any combination of Shared Roadways, Signed Shared Roadways, Bike Paths, Greenways, other routes which provide bicyclists and pedestrians with a suggested alternative route between destinations.



Figure 1

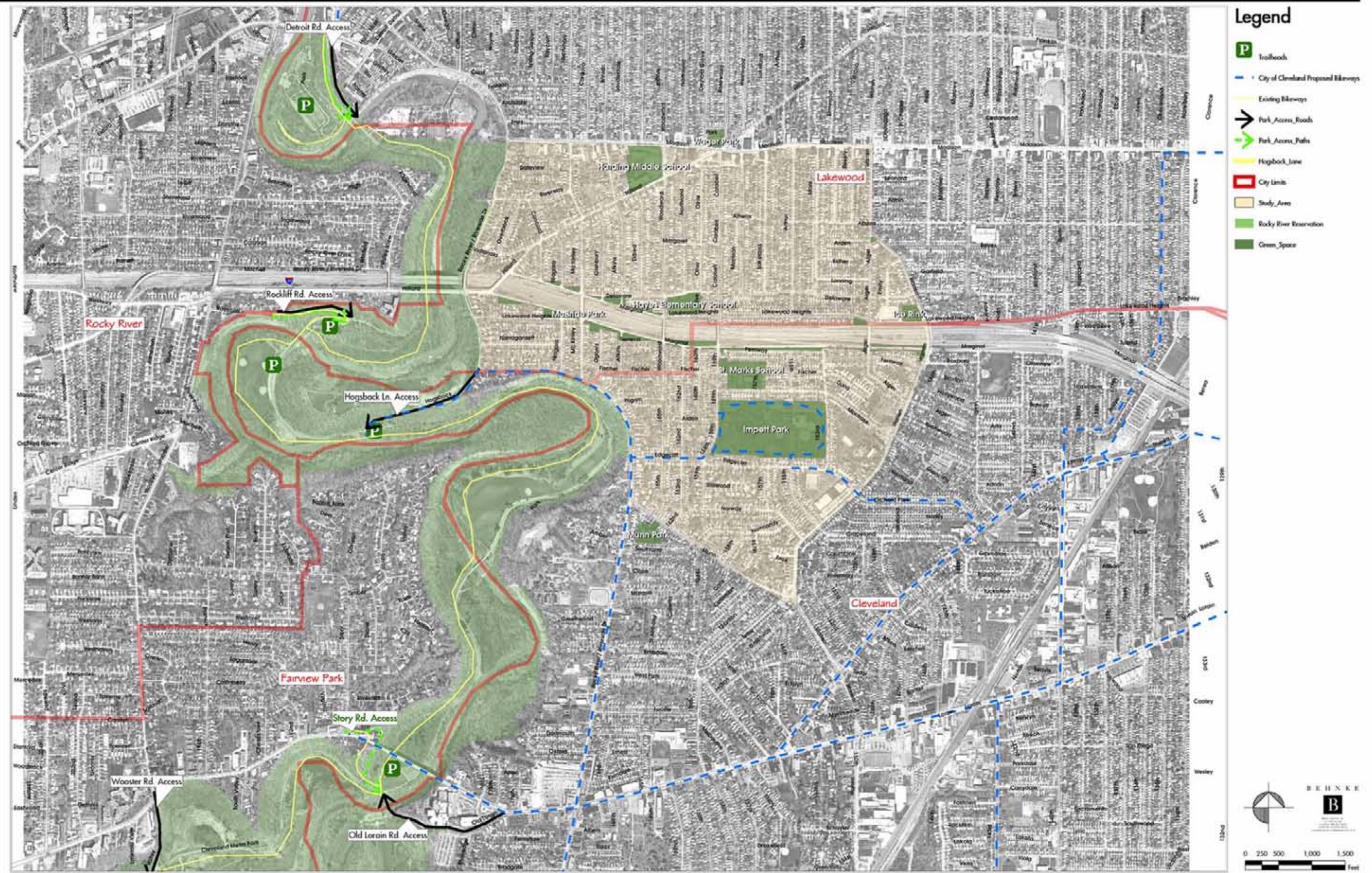

Figure 2

Regional Map

| Barrett Rd | | Falls Ln. | | Sheppard Ln. | |
|--------------|----------------|--------------|---------------|--------------|----------------|
| January | 17,084 | January | 1,185 | January | 14,443 |
| February | 15,926 | February | 1,193 | February | 12,264 |
| March | 18,253 | March | 1,445 | March | 12,845 |
| April | 24,715 | April | 1,909 | April | 14,611 |
| May | 24,693 | May | 1,796 | May | 15,177 |
| June | 24,495 | June | 1,947 | June | 14,490 |
| July | 26,789 | July | 4,089 | July | 16,003 |
| August | 23,584 | August | 1,791 | August | 30,737 |
| September | 11,298 | September | 1,735 | September | 15,355 |
| October | 19,060 | October | 1,618 | October | 14,735 |
| November | 17,472 | November | 1,204 | November | 14,010 |
| December | 16,713 | December | 1,666 | December | 14,218 |
| TOTAL | 240,082 | TOTAL | 21,578 | TOTAL | 188,888 |

| Brookway Ln. | | Wooster Rd. | | Old Lorain Rd. | |
|--------------|----------------|--------------|------------------|----------------|----------------|
| January | 9,003 | January | 89,553 | January | 11,725 |
| February | 8,642 | February | 66,238 | February | 14,382 |
| March | 10,843 | March | 108,725 | March | 19,691 |
| April | 14,234 | April | 76,034 | April | 24,266 |
| May | 12,853 | May | 91,016 | May | 25,035 |
| June | 12,110 | June | 82,205 | June | 25,652 |
| July | 13,032 | July | 102,433 | July | 27,856 |
| August | 25,344 | August | 98,783 | August | 24,390 |
| September | 11,362 | September | 95,783 | September | 24,088 |
| October | 10,862 | October | 92,966 | October | 20,661 |
| November | 9,697 | November | 74,616 | November | 16,516 |
| December | 9,944 | December | 86,088 | December | 20,312 |
| TOTAL | 147,926 | TOTAL | 1,064,440 | TOTAL | 254,574 |

| Hogsback Ln. | | Rockcliff Ln. | | Detroit Rd. | |
|--------------|----------------|---------------|----------------|--------------|----------------|
| January | 20,743 | January | 9,061 | January | 28,445 |
| February | 19,162 | February | 8,542 | February | 25,399 |
| March | 26,092 | March | 11,351 | March | 35,658 |
| April | 34,884 | April | 16,662 | April | 28,097 |
| May | 34,916 | May | 13,208 | May | 27,619 |
| June | 39,892 | June | 12,648 | June | 57,405 |
| July | 47,190 | July | 14,530 | July | 45,558 |
| August | 41,788 | August | 12,699 | August | 43,091 |
| September | 38,082 | September | 12,239 | September | 45,680 |
| October | 27,253 | October | 11,193 | October | 38,852 |
| November | 23,429 | November | 10,003 | November | 32,283 |
| December | 22,737 | December | 10,080 | December | 30,588 |
| TOTAL | 376,168 | TOTAL | 142,216 | TOTAL | 438,675 |

Grand Total
2,874,547

Figure 3



Figure 4

Photo Key Map



A typical narrow bridge that spans I-90

1



Large intersections within the neighborhood side streets.

4



Tight space between existing property lines and South Marginal.

7



Unmarked pavement on Rocky River drive / Riverside drive.

10



Busy intersections within the study area.

2



McKinley Road and Rocky River Drive / Riverside Drive high volume intersection.

5



Under utilized green space between South Marginal and I-90.

8



Parking along Rocky River Drive / Riverside Drive.

11



Where Rocky River Drive / Riverside Drive bridge over I-90.

3



Pinch points at end of South Marginal green space.

6



Hogsback Lane becomes narrow when entering into the Rocky River Reservation.

9



Narrow edge conditions along Rocky River Drive / Riverside Drive.

12

Figure 5

Existing Constraints



Wide pavement along Rocky River Drive / Riverside Drive. 13



Hogsback Lane has ample room to provide a wider and more stable roadbed into the MetroPark. 16



Under utilized linear green space along South Marginal. 19



Existing trails within Impett Park. 22



A typical low traffic side street in the local neighborhood. 14



The vehicle barrier to Indianola Road provides a safe environment for multi-users. 17



Under utilized linear green space along South Marginal. 20



Niagara Park, a small neighborhood green pocket within the heart of the local community. 23



Less active intersections provide safer, more efficient connections to Riverside Road. 15



Barrier wall between the sidewalks and roadway. 18



Under utilized swaths of linear green space along South Marginal. 21



Impett Park, a key feature and greenspace throughout the local neighborhood. 24

Figure 6

Existing Opportunities

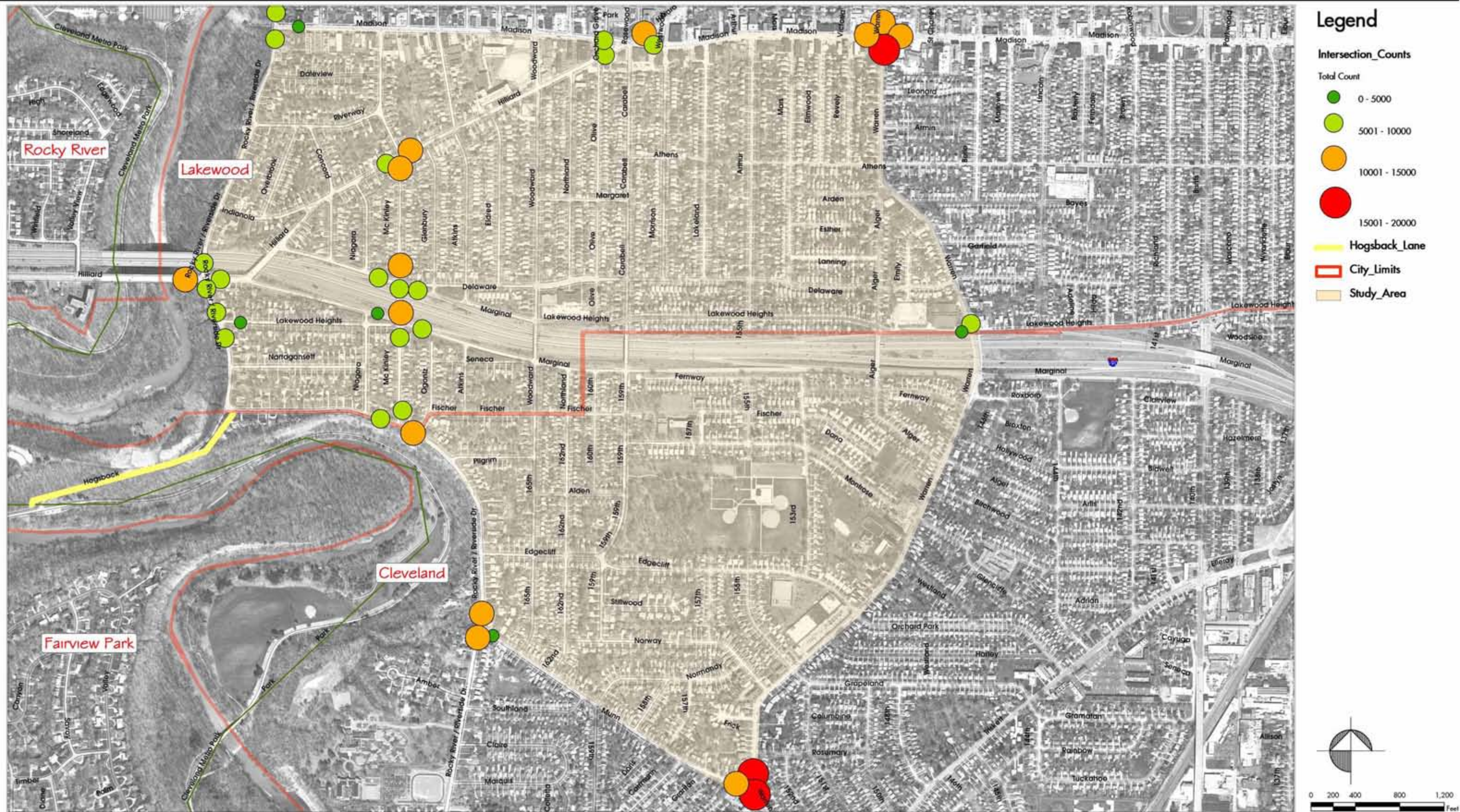

Figure 7

Study Area Average Daily Traffic Counts

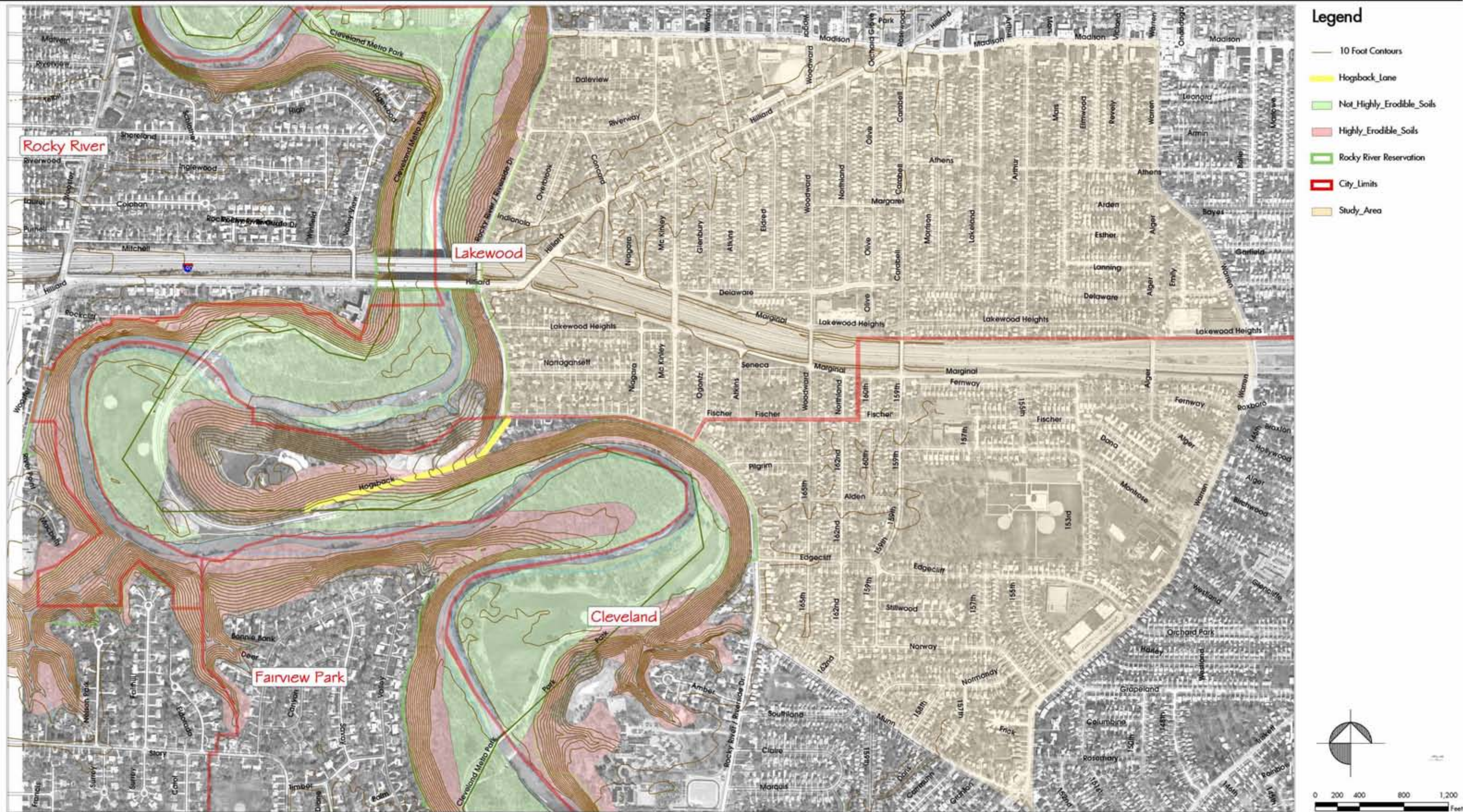

Figure 8



- Legend**
- Hoggsback_Lane
 - City_Limits
 - Study_Area
 - Green_Space

BEINKE
B

Beinke Associates, Inc.
Landscape Architects/Planners
12245 West 98th Street
Overland Park, KS 66204
P: 913.241.1100
www.beinke.com

0 100 200 400
Foot

Figure 9

| Idea # | Number of votes | Idea | Pro's | Con's |
|---------------|------------------------|--|---|---|
| 1 | 31 | Improve intersection at top of Hogsback. | See Recommendations section of report | See Recommendations section |
| 2 | 17 | Enhance existing trails (Sharkey's and Cowpath) into Metropark from Riverside / Rocky River Drive for off-road biking and cross-country running. | <input type="checkbox"/> Provides more access to reservation for cross country runners and mountain bikers. <input type="checkbox"/> Opens up unused area of reservation to users. | <input type="checkbox"/> Steep routes. <input type="checkbox"/> Requires considerable regrading, stabilization, railings, and maintenance along former path alignment. |
| 3 | 14 | Create all-purpose trail on west side of Riverside / Rocky River Drive from Madison to Hogsback with decorative wall / railing. | <input type="checkbox"/> Creates separate trail for users, along busy Riverside Drive. <input type="checkbox"/> Room along most of length to build path outside of existing curb and/or on portion of wide Riverside lane. | <input type="checkbox"/> Relatively costly. <input type="checkbox"/> Little room for trail at existing bridge over I-90. |
| 4 | 11 | Create overlooks along Riverside/Rocky River Drive, for viewing reservation and wildlife. | <input type="checkbox"/> Easy to build individual overlooks, as money becomes available. <input type="checkbox"/> Opens up underutilized views to reservation. <input type="checkbox"/> Could be done inexpensively. | <input type="checkbox"/> None |
| 5 | 7 | Build a pedestrian bridge over I-90, between St. Mark's Elementary and Hayes Elementary. | <input type="checkbox"/> Provides a safe route for children and families to traverse I-90 to get to their school. <input type="checkbox"/> Provides a safe route for Hogsback users to traverse I-90. | <input type="checkbox"/> Costly. |
| 6 | 6 | Create bike lane on Riverside / Rocky River Drive, from Munn to Hogsback. | <input type="checkbox"/> Room to easily add bike lane. <input type="checkbox"/> Relatively inexpensive. | <input type="checkbox"/> Potential conflict with cars parked on Riverside. |
| 7 | 4 | Repair Hogsback to prevent water flowing over road, and freezing in winter. | <input type="checkbox"/> Good stop gap measure to make users on current Hogsback Lane safer. <input type="checkbox"/> Relatively inexpensive fix. | <input type="checkbox"/> A stop gap measure. |
| 8 | 3 | Make McKinley one-way, to reduce traffic volume generated by Interstate 90. | <input type="checkbox"/> Reduces traffic volume on McKinley | <input type="checkbox"/> Costly <input type="checkbox"/> A difficult sell to ODOT and local traffic agencies. |
| 9 | 2 | Post speed limits on Hogsback. | <input type="checkbox"/> Could help slow vehicular traffic. <input type="checkbox"/> Inexpensive. | <input type="checkbox"/> None |
| 10 | 2 | Improve multi-user crossings onto Riverside/Rocky River Drive. | <input type="checkbox"/> Provides safer access for residents to get on and off of Riverside/Rocky River. | <input type="checkbox"/> None |
| 11 | 1 | Provide traffic calming on North and South Marginals. | <input type="checkbox"/> Will slow vehicular traffic down, and create safer environment for multi-users. <input type="checkbox"/> Some traffic calming methods can be inexpensive. | <input type="checkbox"/> Some traffic calming methods can be expensive. |
| 12 | 1 | Create/enhance pedestrian crossings on existing Woodward/W. 165 th St. & Carabe/W. 159th St. bridges over I-90. | <input type="checkbox"/> Provides a safe route for children and families to traverse I-90 to get to their school. <input type="checkbox"/> Provides a safe route for Hogsback users to traverse I-90. | <input type="checkbox"/> Relatively costly. |
| 13 | 1 | Direct people through the "Green Core" (Impett Park, St. Mark's Elementary, and Hayes Elementary) on way to Hogsback. | <input type="checkbox"/> Maximizes use of existing green space. <input type="checkbox"/> Provides pleasant, leisurely route to Hogsback. | <input type="checkbox"/> Less direct route to Hogsback for many study area residents. |
| 14 | 1 | Install all-purpose trail along the 153rd Street side of Impett Park. | <input type="checkbox"/> Serves the dual purpose of adding sidewalk, where there currently is no sidewalk, and constructing a segment of bikeway to Hogsback. | <input type="checkbox"/> Serves a small portion of the study area. |
| 15 | 1 | Improve crosswalks at key intersections. | <input type="checkbox"/> Inexpensive and easy to do. | <input type="checkbox"/> None |
| 16 | 1 | Add trash receptacles at key locations. | <input type="checkbox"/> Inexpensive and easy to do. | <input type="checkbox"/> None |
| 17 | 1 | Install traffic cameras at key locations. | <input type="checkbox"/> Slows traffic at the specific camera location. | <input type="checkbox"/> Costly |
| 18 | 1 | Clarify who has what right of way on Hogsback with signage | <input type="checkbox"/> Inexpensive and easy to do. | <input type="checkbox"/> None |
| 19 | 1 | Provide access to prairie at bottom of Stichcomb Drive. | <input type="checkbox"/> Could be done inexpensively. <input type="checkbox"/> Opens up under-utilized area. | <input type="checkbox"/> None |
| 20 | 0 | Build an all-purpose trail along South Marginal on excess ODOT Right-of-Way. | <input type="checkbox"/> Takes advantage of under-utilized green space. <input type="checkbox"/> Green strip is contiguous along majority of South Marginal. | <input type="checkbox"/> Could be costly. <input type="checkbox"/> Some areas of the strip get very narrow. |
| 21 | 0 | Build a pedestrian bridge over I-90, west of McKinley. | <input type="checkbox"/> Provides a safe route for children and families to traverse I-90 to get to their school. <input type="checkbox"/> Provides a safe route for Hogsback users to traverse I-90. | <input type="checkbox"/> Costly. <input type="checkbox"/> Location is less logical than between St. Mark's Elementary and Hayes Elementary. |
| 22 | 0 | Provide better handicap access ramps on bridges across I-90. | <input type="checkbox"/> Relatively easy and inexpensive. | <input type="checkbox"/> None |

Figure 10

Public Meeting #1 and 2 Ideas
(in order of number of votes)



Figure 11



Figure 12



Figure 13

What are The Most Important Destinations?

Place Up To Two Dots At The Destinations Most Important To You.

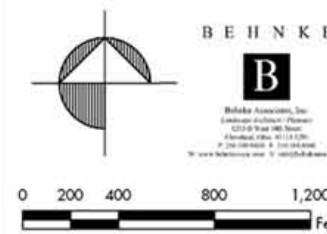
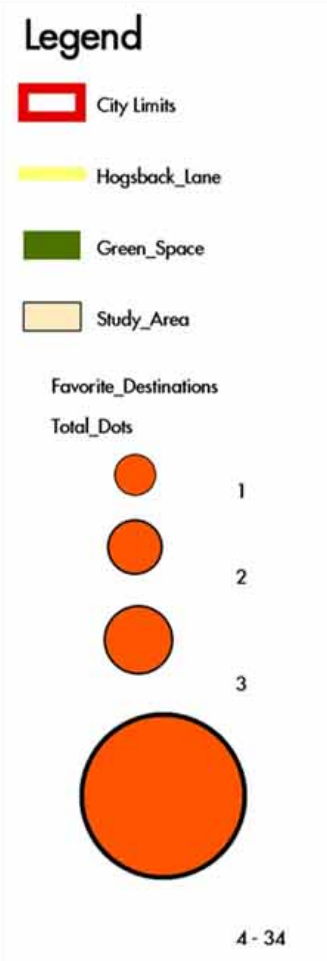

Figure 14

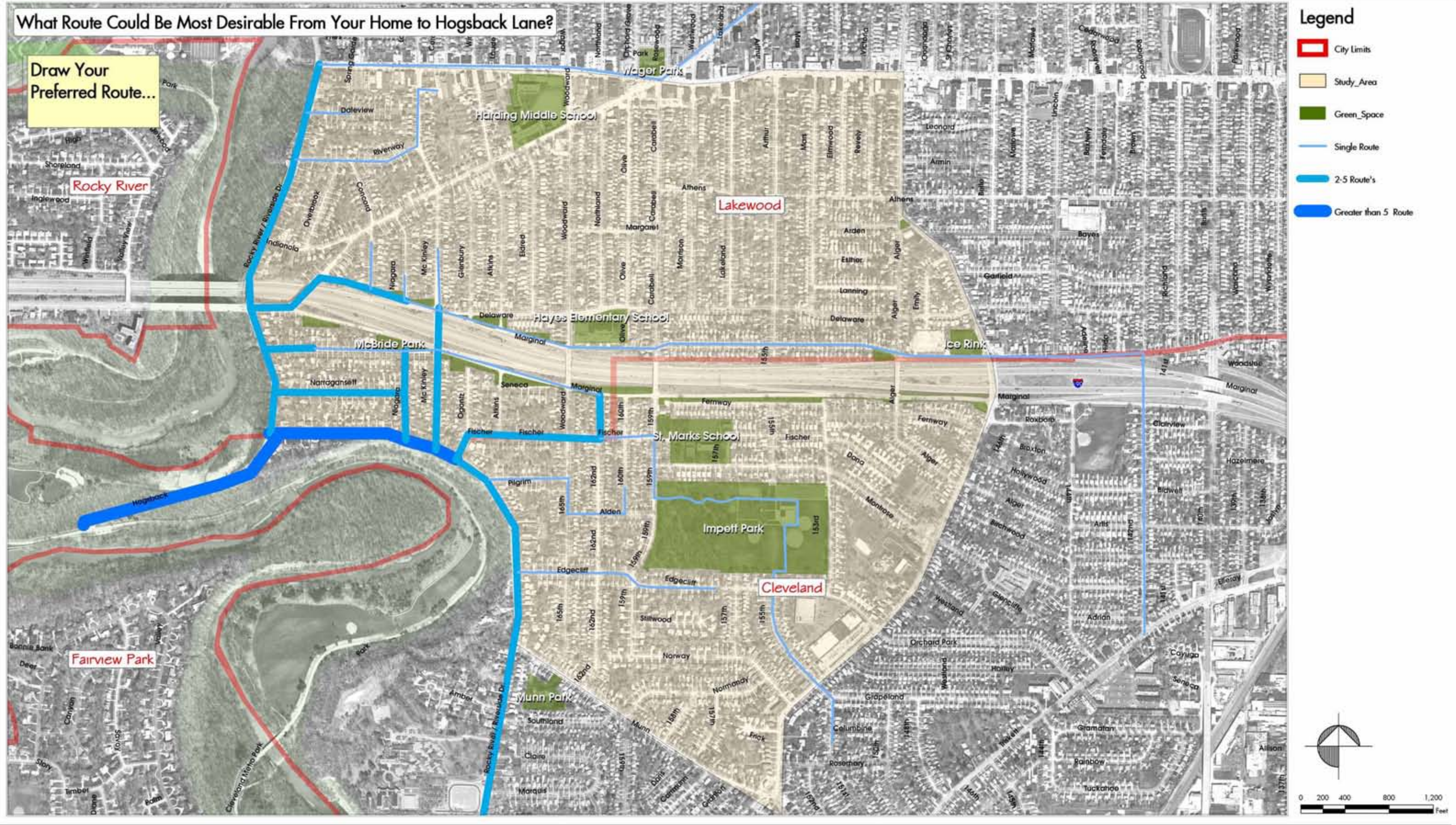

Figure 15

Public's Preferred Routes to Hogsback





| Preference | Option |
|------------|---|
| 0 VOTES | <p data-bbox="428 226 781 268">1. Leave it alone.</p>  |
| 15 VOTES | <p data-bbox="428 436 1382 478">2. Upgrade roadway, widen, and add bike lane.</p>  |
| 12 VOTES | <p data-bbox="428 680 1349 722">3. Upgrade roadway and add all-purpose trail</p>  |
| 1 VOTE | <p data-bbox="428 924 1130 966">4. Upgrade roadway and ban cars.</p>  |
| 1 VOTE | <p data-bbox="428 1167 1386 1255">5. Upgrade roadway, allow only one-way traffic downhill, and add all-purpose trail.</p>  |
| 0 VOTES | <p data-bbox="428 1465 1430 1554">6. Upgrade roadway and only allow car access to Stinchcomb monument.</p>  |

Figure 16

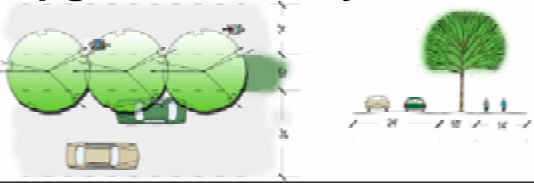
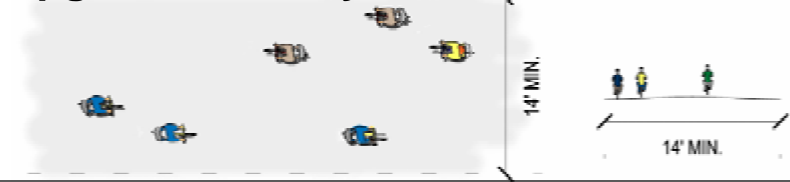
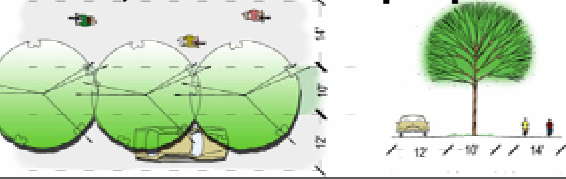
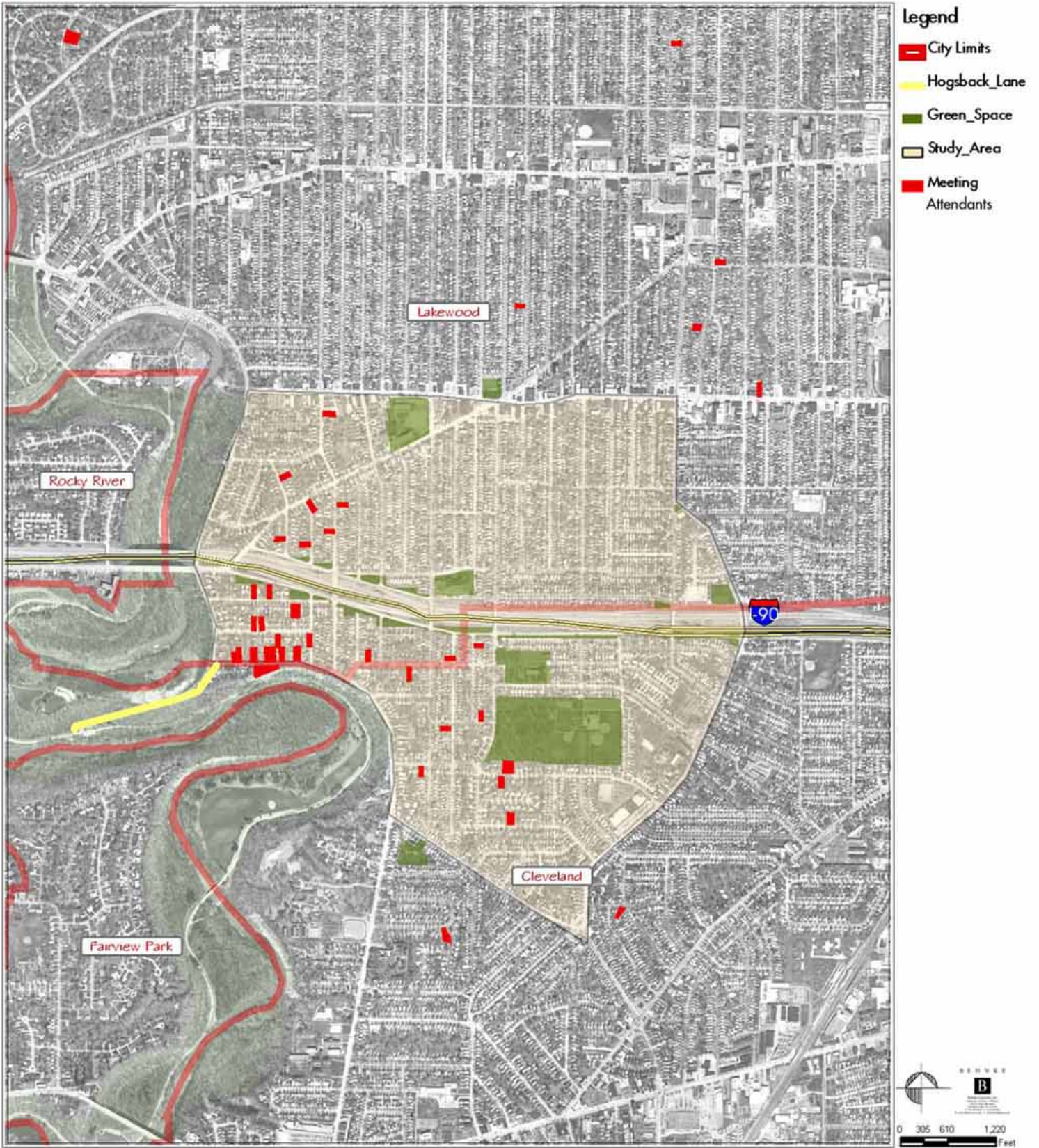

Figure 17

Geographic Distribution of all Public Meeting Participants

| # | Recommendation | Estimated Costs | Estimated Costs | Estimated Costs | Estimated Costs | Estimated Costs | Estimated Costs | Estimated Costs | Estimated Costs |
|---------------|--|--------------------|--------------------|--------------------|--------------------|--------------------|--------------------|--------------------|--------------------|
| 1 | Signed bike route along Hilliard | 1,000 | 1,000 | 1,000 | 1,000 | 1,000 | 1,000 | 1,000 | 1,000 |
| 2 | Signed bike routes on Carabel and Lakewood Heights to Riverside | 1,000 | 1,000 | 1,000 | 1,000 | 1,000 | 1,000 | 1,000 | 1,000 |
| 2a | Widened 159th St. bridge, Option #1 | 530,000 | | | | 530,000 | | | |
| 2b | Widened 159th St. bridge, Option #2 | | 830,000 | | | | 830,000 | | |
| 2c | On new multi-user bridge | | | 1,230,000 | | | | 1,230,000 | |
| 3 | Signed bike routes on Edgediff and all-purpose trails in Impett Park | 25,000 | 25,000 | 25,000 | 25,000 | 25,000 | 25,000 | 25,000 | 25,000 |
| 4 | Southwest residents take local streets to Riverside | 0 | 0 | 0 | 0 | 0 | 0 | 0 | 0 |
| 5 | Riverside Drive bike lanes | 10,000 | 10,000 | 10,000 | 10,000 | 10,000 | 10,000 | 10,000 | 10,000 |
| | Riverside Drive (South of Hogsback) traffic calming | 75,000 | 75,000 | 75,000 | 75,000 | 75,000 | 75,000 | 75,000 | 75,000 |
| 6 | Riverside Drive all-purpose trail | 350,000 | 350,000 | 350,000 | 350,000 | 350,000 | 350,000 | 350,000 | 350,000 |
| | Riverside Drive (North of Hogsback) traffic calming and crosswalks | 120,000 | 120,000 | 120,000 | 120,000 | 120,000 | 120,000 | 120,000 | 120,000 |
| 6a | Widened Riverside bridge, Option #1 | 700,000 | 700,000 | 700,000 | | | | | |
| 6b | Widened Riverside bridge, Option #2 | | | | 1,000,000 | 1,000,000 | 1,000,000 | 1,000,000 | 1,000,000 |
| 7 | (2) Overlooks | 50,000 | 50,000 | 50,000 | 50,000 | 50,000 | 50,000 | 50,000 | 50,000 |
| 8 | Rehabilitate Sharkey's Hill and Cow Path foot trails | 35,000 | 35,000 | 35,000 | 35,000 | 35,000 | 35,000 | 35,000 | 35,000 |
| 9 | Hogsback improvements | 2,000,000 | 2,000,000 | 2,000,000 | 2,000,000 | 2,000,000 | 2,000,000 | 2,000,000 | 2,000,000 |
| 10 | Hogsback/Riverside intersection improvements | 400,000 | 400,000 | 400,000 | 400,000 | 400,000 | 400,000 | 400,000 | 400,000 |
| Totals | | \$4,297,000 | \$4,597,000 | \$4,997,000 | \$4,597,000 | \$4,597,000 | \$4,897,000 | \$4,897,000 | \$5,297,000 |

Figure 18

Summary of Recommendations

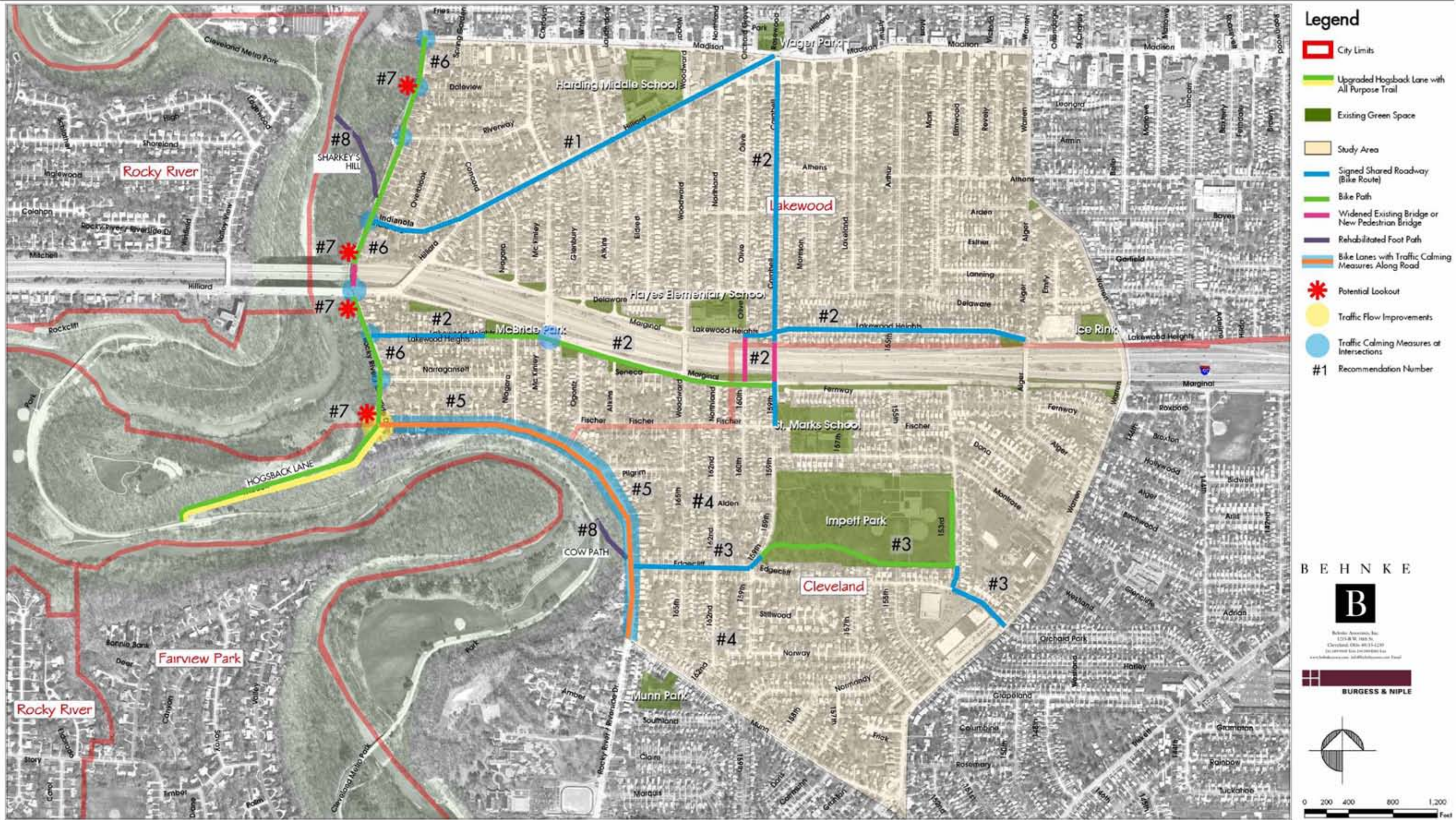
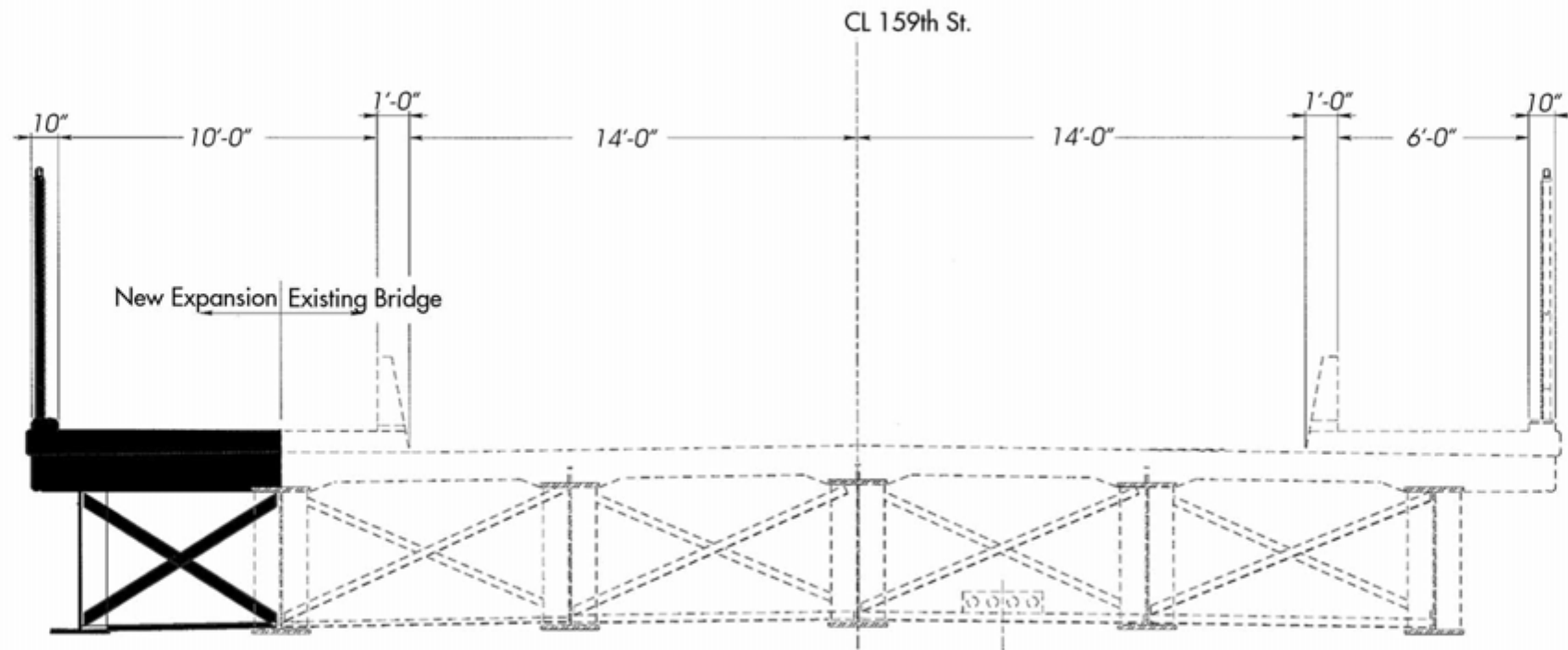
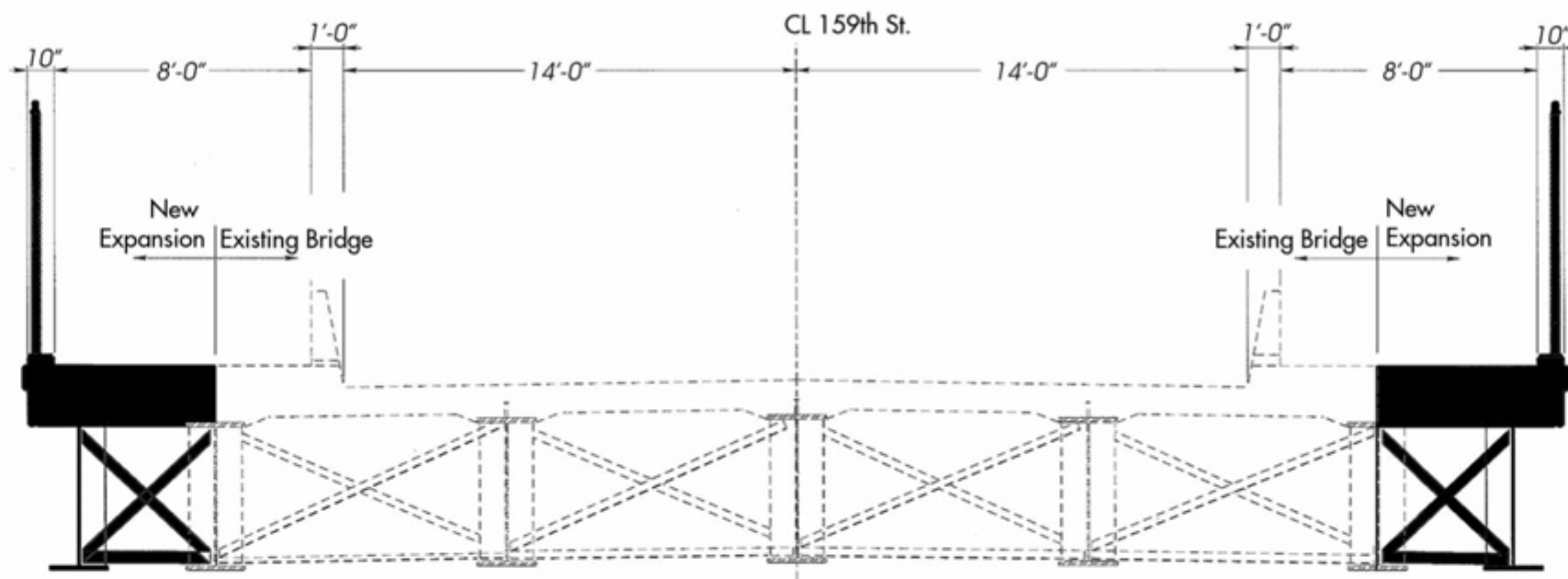

Figure 19

Hogsback Lane Access Master Plan



Option 1 - 10' one side widening.



Option 2 - 8' both sides widening.

Figure 20

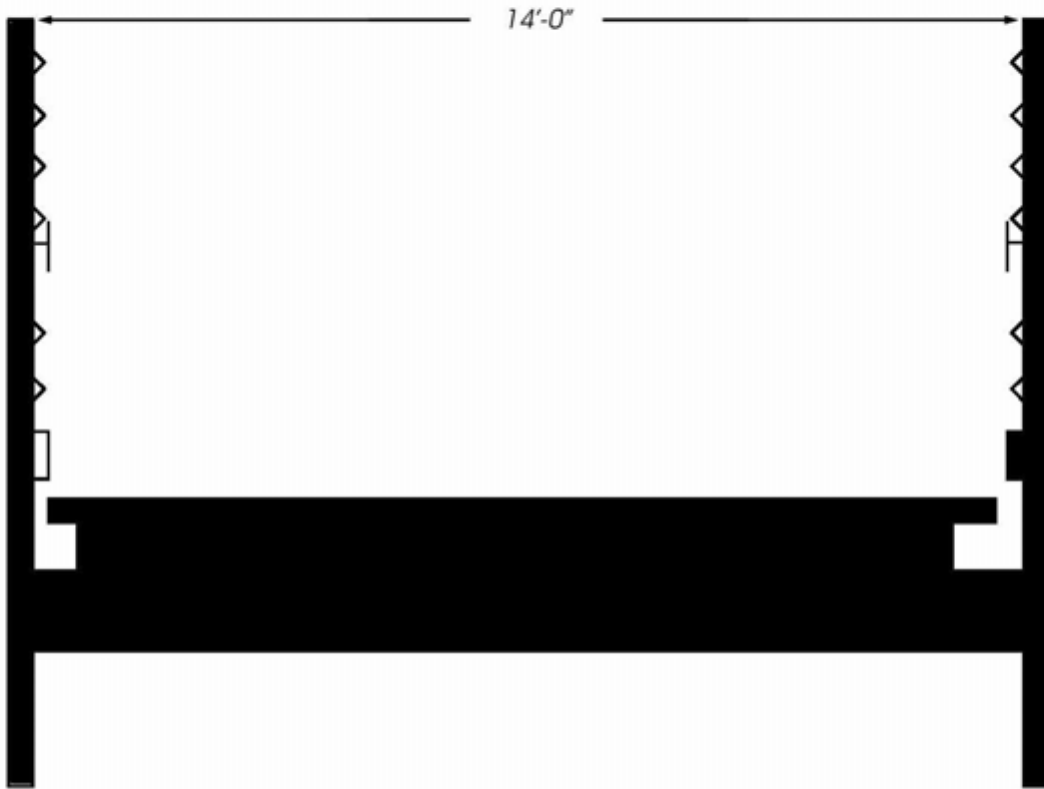

Pre-Engineered Steel Bridge

Figure 21

Intersections



Roundabout



Raised Intersection



Colored / Textured Pavement

Roadways



Center Island Narrowing



Raised Crosswalks



Speed Monitoring



Neckdown



Speed Hump



Choker

Figure 22

Traffic Calming Examples

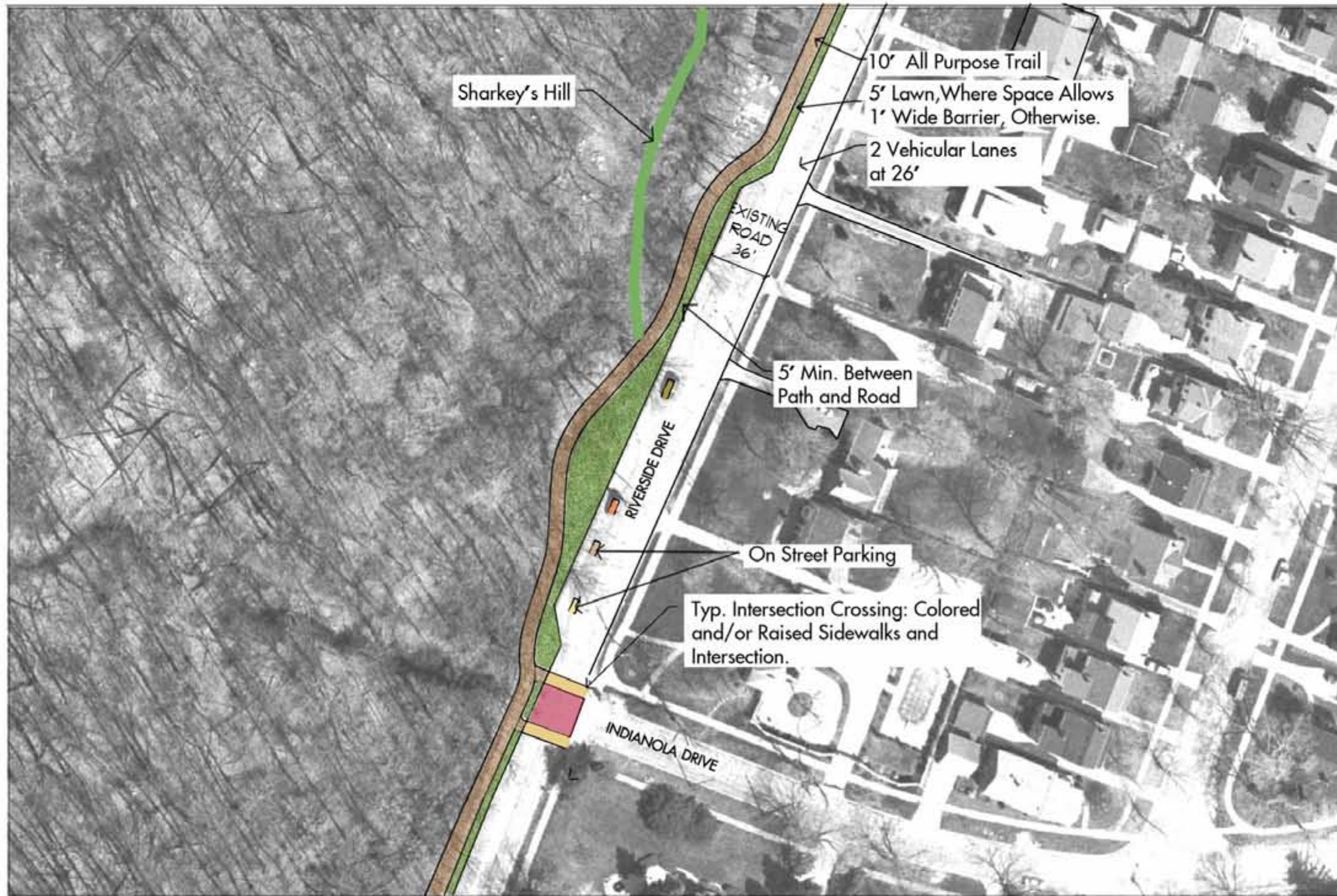
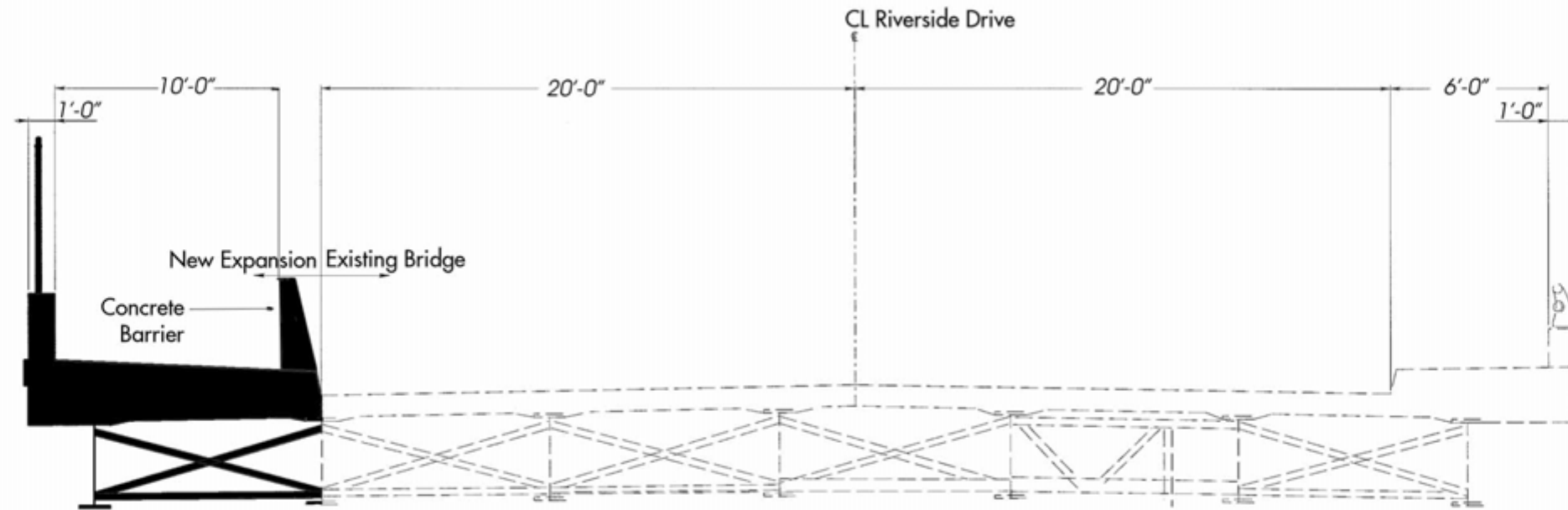
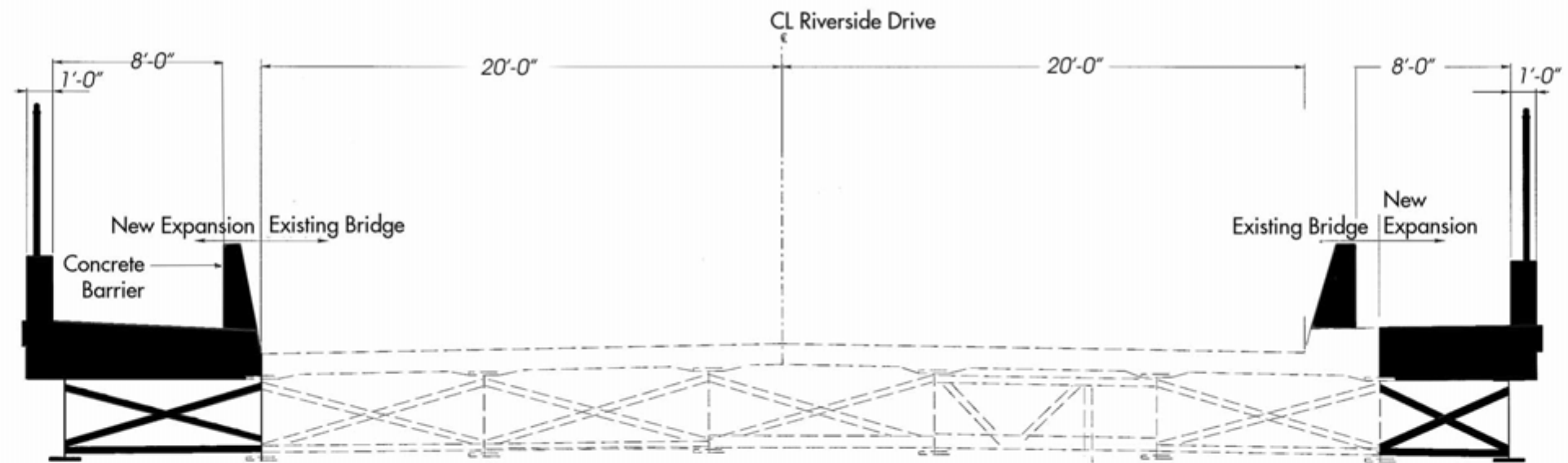

Figure 23



Option 1 - 10' one side widening.



Option 2 - 8' both sides widening.

Figure 24

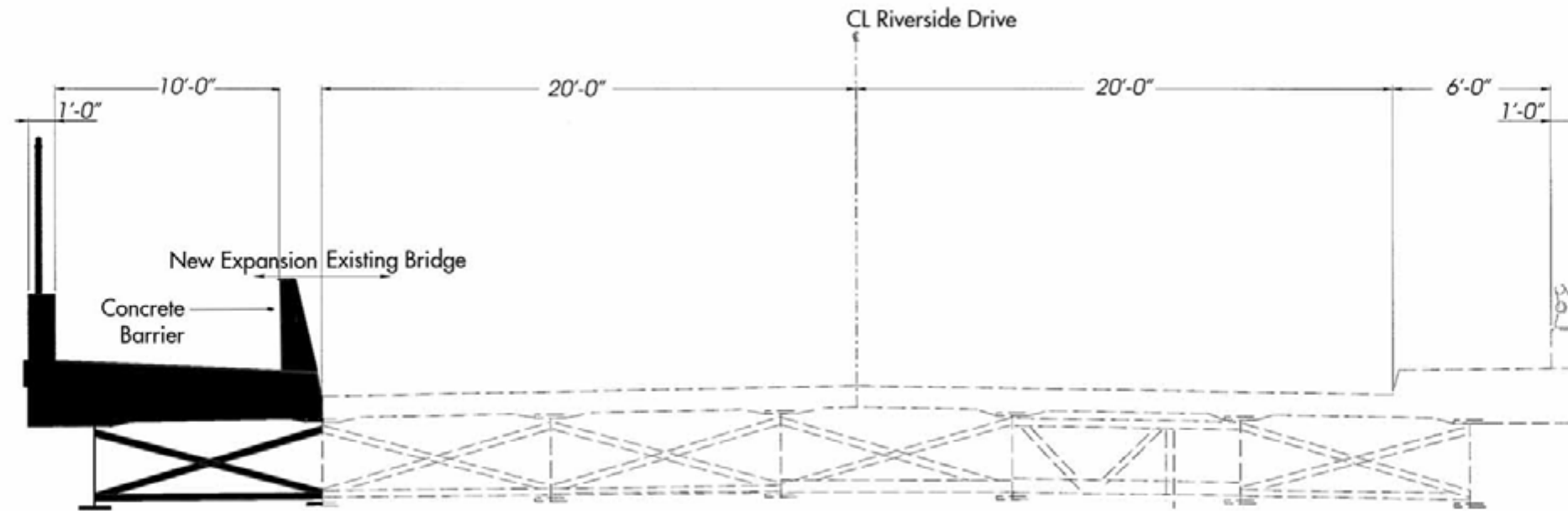

Option 1 - 10' one side widening.

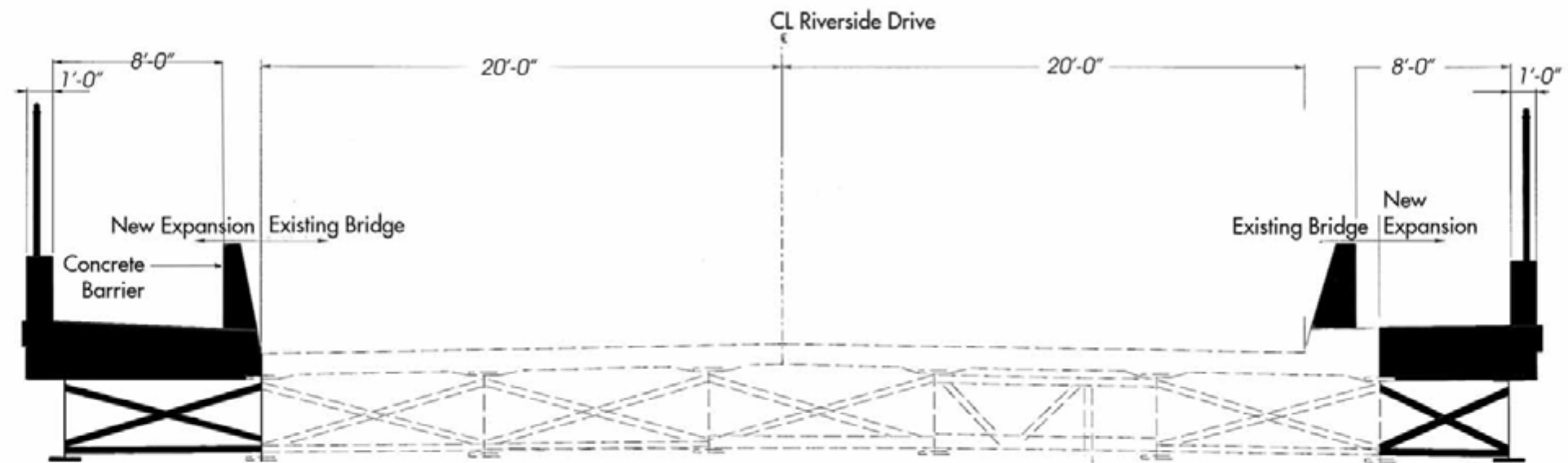

Option 2 - 8' both sides widening.

Figure 24



Figure 25

Hogsback Lane Improvements,
Hogsback Intersection Improvements
& Bike Lanes on Riverside Drive